

UniPack compact secondary substations
(CSS) upto 36 kV
For safe, reliable and space saving power
distribution solutions

ABB – a global leader

ABB is a global leader in power and automation technologies that enable utility and industry customers to improve performance while lowering environmental impact. The ABB Group of companies operates in around 100 countries.

In India, ABB has a vast installed base, extensive manufacturing facilities and a countrywide marketing and service presence.

The power technologies business offers electric, gas and water utilities as well as industrial and commercial customers a wide range of products, systems and services for power generation, transmission and distribution. ABB's turnkey solution capabilities in the sector range from bulk power transmission, turnkey substations and complete electrification to utility automation and distribution systems.

Our product offering covers a wide spectrum of technologies across the entire voltage range including indoor and outdoor circuit breakers, air and gas insulated switchgear, instrument transformers, disconnectors, capacitor banks, reactive power compensators, power and distribution transformers and a range of power distribution products like compact secondary substations (CSS) and ring main units (RMU).

Commitment to quality and sustainability

ABB manufacturing facilities conform to the highest quality and environmental standards. The facilities are ISO 9001 and ISO 14001 compliant and certified by leading international authorities.

ISO 9001 - 2008 Quality Systems

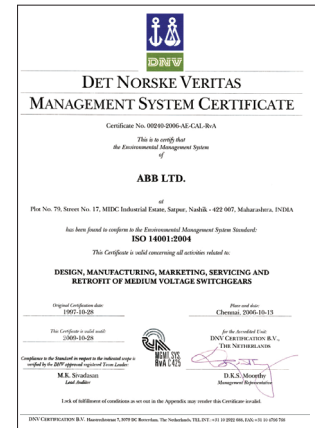

Typical distribution network

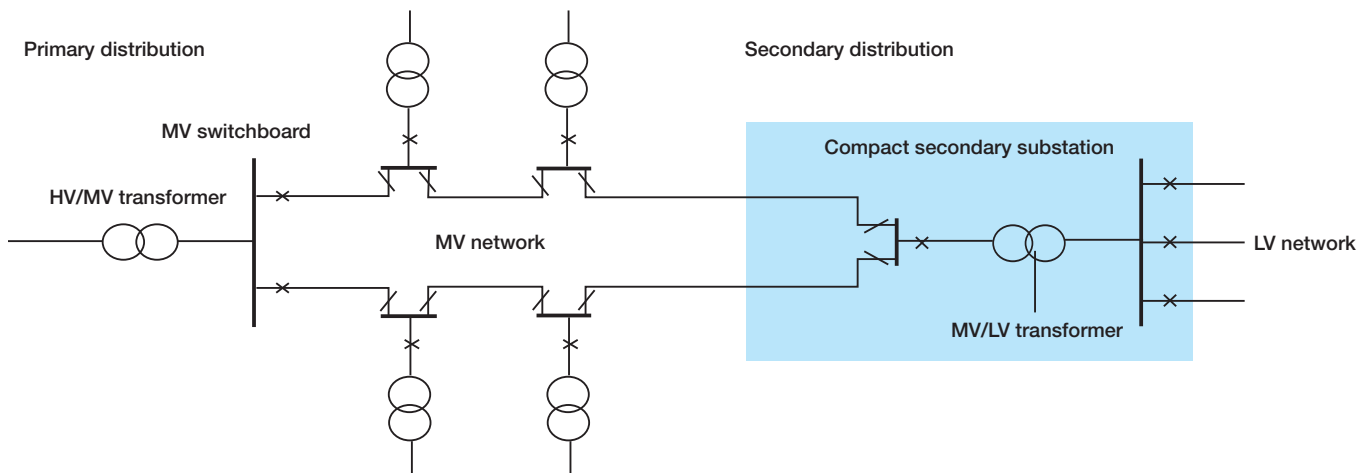

Technology advantage

CSS is a prefabricated substation, factory-designed, tested and ready-to-install and is fully compliant with IEC 62271-202 (IEC 61330). Our compact substations are engineered to the highest possible standards for personnel safety and aesthetics, designed to help solve problems of footprint and space limitations experienced within dense urban load centers.

ABB's CSS has the highest installation base in India as well as around the world.

Salient features

- Modular construction of enclosure provides high degree of flexibility to meet specific site requirements
- Fully compartmentalized construction for MV switchgear, transformer and LV switchgear
- Specially designed ventilation system to suit local climatic conditions
- Appealing aesthetics
- Safety ensured for operator, public and environment
- Low life-cycle cost

Product portfolio

Outdoor CSS for secondary distribution up to 36kV configuration

- MV switchgear
- Step-down distribution transformer
- LV switchgear

Outdoor CSS for wind power evacuation at 36kV configuration

- LV switchgear
- Step-up distribution transformer
- MV switchgear

Indoor frame mounted CSS for secondary distribution up to 24kV configuration

- MV switchgear
- Step-down dry type distribution transformer
- LV switchgear
- Transformer enclosure type-tested for IP2X and enclosure class k10
- Customized design to suit site conditions
- Factory-designed and tested interconnections



CSS for outdoor application



Frame mounted CSS for indoor application

Advanced construction for CSS enclosure

The enclosure of the outdoor CSS is manufactured using high quality pre-galvanized sheet steel. This provides high resistance to corrosion, which is paramount in outdoor applications. CSS is typically divided into three compartments for - medium voltage switchgear, low voltage switchboard and distribution transformer. The detachable roof with ventilation opening is beam supported and secured at each corner with bolts.

Modular construction

The enclosure's wall units, roof and doors are constructed using standard modules. Its limiting dimensions are 3830 x 2330 x 2415 mm (L x W x H)

Advantages:

- High mechanical strength
- Flexibility in design, different layout possible
- Appealing aesthetics

Clinching technology

Self-interlocking modules are inter-connected using clinching technology. All load bearing members are of 2 mm thickness and non-load bearing members are 1.5 mm thick.

Bolting is used only for the base frame and lifting fittings.

Advantages:

- New-age technology, free from rivets and screws
- Piercing of sheet metal is eliminated
- Enhances mechanical strength of CSS enclosure
- Water and air-tight joints

Painting

Enclosure is painted with polyurethane paint.

Advantages:

- Aesthetic, glossy finish
- Outdoor durability
- Resistant to corrosion
- Resistant to chemicals and stains
- Abrasion resistant

Ventilation

Ventilation is achieved by means of natural air circulation from the louvers of wall/door to the top of the roof using thermo siphon effect. Sufficient cooling of distribution transformers is achieved by means of ventilation openings in the transformer compartment, which is designed taking into consideration the transformer rating, losses and climatic conditions. A standard CSS is classified and type-tested in accordance with enclosure class requirement.

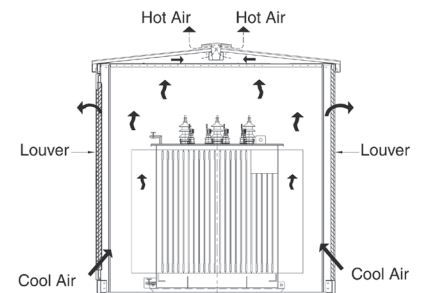

Doors and locking system

All compartment doors are fixed with stainless steel hinges, which provide high mechanical strength. Press-fit type gaskets ensure IP protection. Locks are equipped with concealed shooting bolt arrangement and complete with a magnetic flap. A padlock is also provided to protect against vandalism.

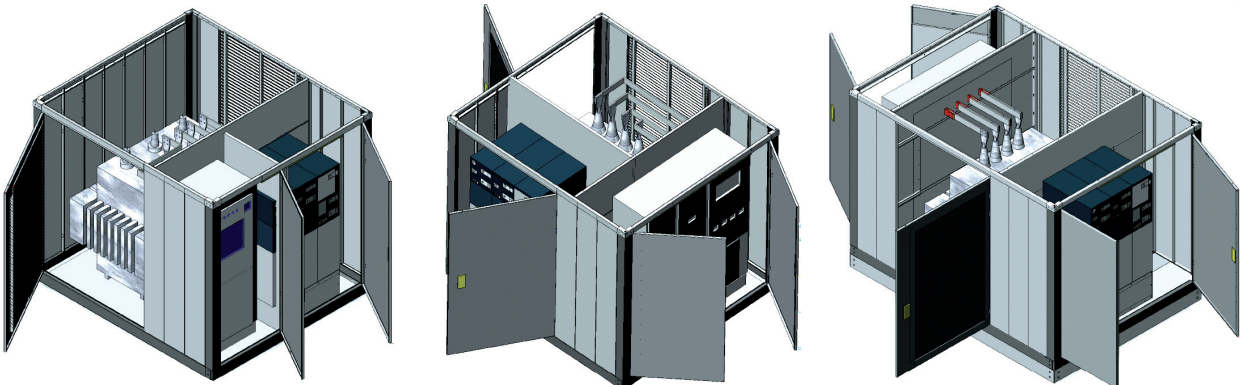

Example of different CSS layouts

Flexible electrical composition

Medium voltage switchgear

The MV compartment can be equipped with SF₆ insulated compact Switchgear Type Safe Ring upto 36kV.

For 36kV Compact Secondary Substation, air insulated switchgear with vacuum circuit breaker can also be offered.

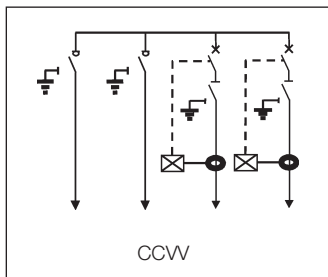
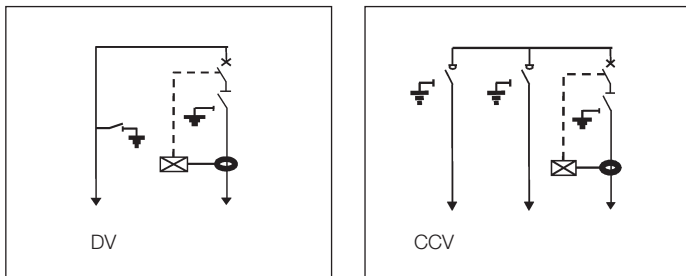

SafeRing switchgear is available with vacuum circuit-breaker and fuse protection

Distribution transformer

Oil-type transformer

Oil-insulated transformer can be provided with CSS up to 36kV. Fully hermetically sealed transformer with low losses and low temperature rise are used in CSS.

- Corrugated-wall type design without conservator
- Leak-proof design due to elimination of conservator
- Eliminates routine maintenance activities such as breather-checking, periodical oil-testing and filtration.
- High efficiency design with low loss and low temperature rise



Dry-type transformer

- Dry-type transformers can be provided with CSS up to 24kV

Advantages of dry-type transformer:

- Resin is used as the insulating medium for longer life
- Maintenance-free
- No fire hazards
- Enhanced safety
- Environment-friendly



Low voltage switchboard

A fully customized solution type-tested as per IS/IEC standards is provided as per customer requirements. The low voltage switchboard can be designed in different arrangements and configurations in order to suit a specific application with required equipment such as:

- Air circuit-breaker (ACB)
- Moulded case circuit-breaker (MCCB)
- LV fuse switches / fuse ways
- Instrumentation and metering
- Automatic transfer schemes (ATS)
- Street lighting systems



Internal earthing

The earthing of the CSS is made by 50 x 6 mm GI strip. The continuity of earth system is ensured taking into account the thermal and mechanical stresses.

Connection between equipment

Personnel and equipment safety is the major concern. In order to ensure complete safety of equipment used in a CSS, especially the transformer bushings, the connection between the transformer and the RMU is made with XLPE insulated cables. The connection between the transformer and LVDB is made with cable / busbar.

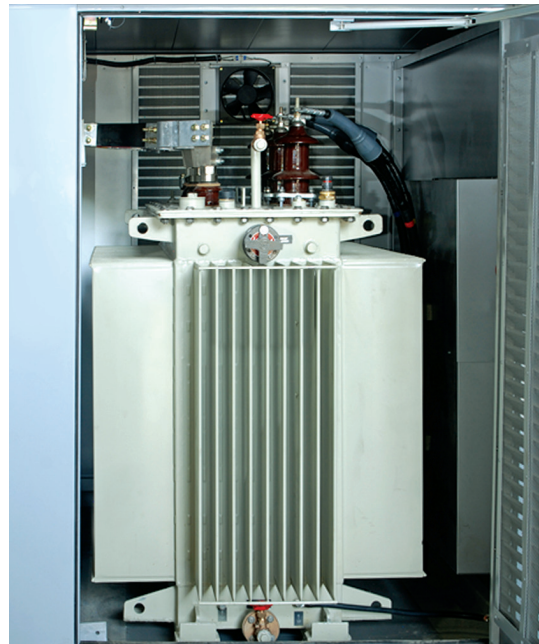

Optional features

- Tariff metering for MV in a separate compartment
- Automatic Power Factor Correction Panel on LV side
- Smoke detector and fire alarm system for transformer compartment
- Motor operation of LV and MV equipment for SCADA connectivity
- Special enclosure colour options for outdoor CSS
- Touch-proof plug-in MV terminations for transformers

CSS electrical characteristics

	Outdoor CSS up to 24kV	Outdoor CSS for 36kV	Indoor frame mounted CSS up to 24kV
Standard applicable	IEC 62271 – 202 (IEC 61330)	IEC 62271 – 202 (IEC 61330)	MV Switchgear – IEC 62271 - 200 / 60265 / 60694 Transformer - IEC 60076 / 60726 LV Switchgear – IEC 60439
Normal ambient temperature	40 ° C	40 ° C	40 ° C
Maximum ambient temperature	50 ° C	50 ° C	50 ° C
Enclosure construction	Modular	Modular	Modular for Transformer compartment
Ventilation	Natural	Natural	Natural
Temperature class (Std.)	K 10	K 10	K 10
Degree of protection			
MV and LV compartment	IP 54	IP 54	NA
Transformer compartment	IP 23	IP 23	IP 2X
MV Switchgear			
Rated voltage (kV)	12/24kV	36kV	12 / 24kV
Rated insulation level			
Power frequency (kV rms)	28/50	70	28 / 50
Impulse (kV p)	75/125	170	75 / 125
Rated frequency (Hz)	50	50	50
Isolator			
Rated normal current (A)	630	630	630
Breaking capacity (A)	630	630	630
Making capacity (kA)	52.5 / 40	50	52.5 / 40
Vacuum circuit breaker			
Rated normal current (A)	630	630	630
Breaking capacity (kA)	21/16	20	21 / 16
Making capacity (kA)	52.5 / 40	50	52.5 / 40
Transformer			
Rated power (kVA) – oil type	1600	2000	NA
Rated power (kVA) – Dry type	2000	2000	2000
Rated secondary voltage (V)	433	433	433
Vector group	Dyn 11	Dyn 11	Dyn 11
Tapping range	± 5 in steps of 2.5%	± 5 in steps of 2.5%	± 5 in steps of 2.5%
Type test			
IP	Yes	Yes	Yes (For transformer compartment)
Internal arc	Yes	Yes	NA
Enclosure class	Yes	Yes	Yes
Impact test	Yes	Yes	NA
Short circuit test on earthing	Yes	Yes	NA

Contact us

ABB Limited operates a process of continuous product development. We therefore reserve the right to change designs, dimensions and data without prior notice.



ABB LIMITED



Head Office :
333, Gala Complex,
Dindayal Upadhy Marg,
Mulund (W). Mumbai - 400 080.
India.

Tel. : + 91 - 22 - 25903232

TeleFax : +91 - 22 - 590 3434

Mobile : +91 - 9867888717 / +91 - 9892533737

www.chiragtec.com

email : chiragtec@gmail.com